

Installation Manual

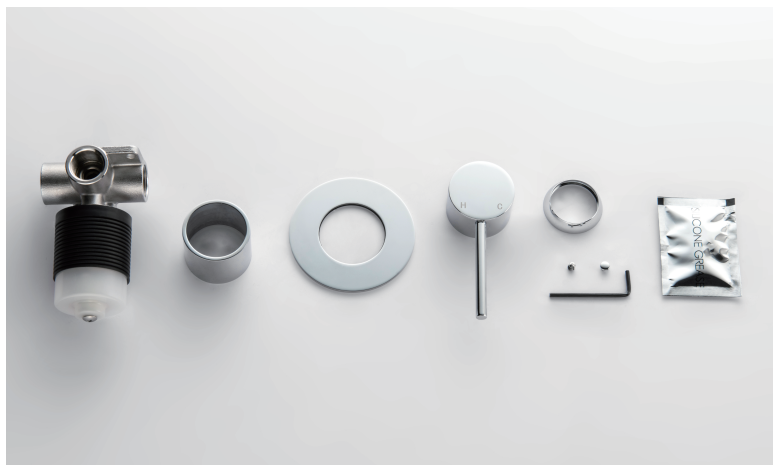
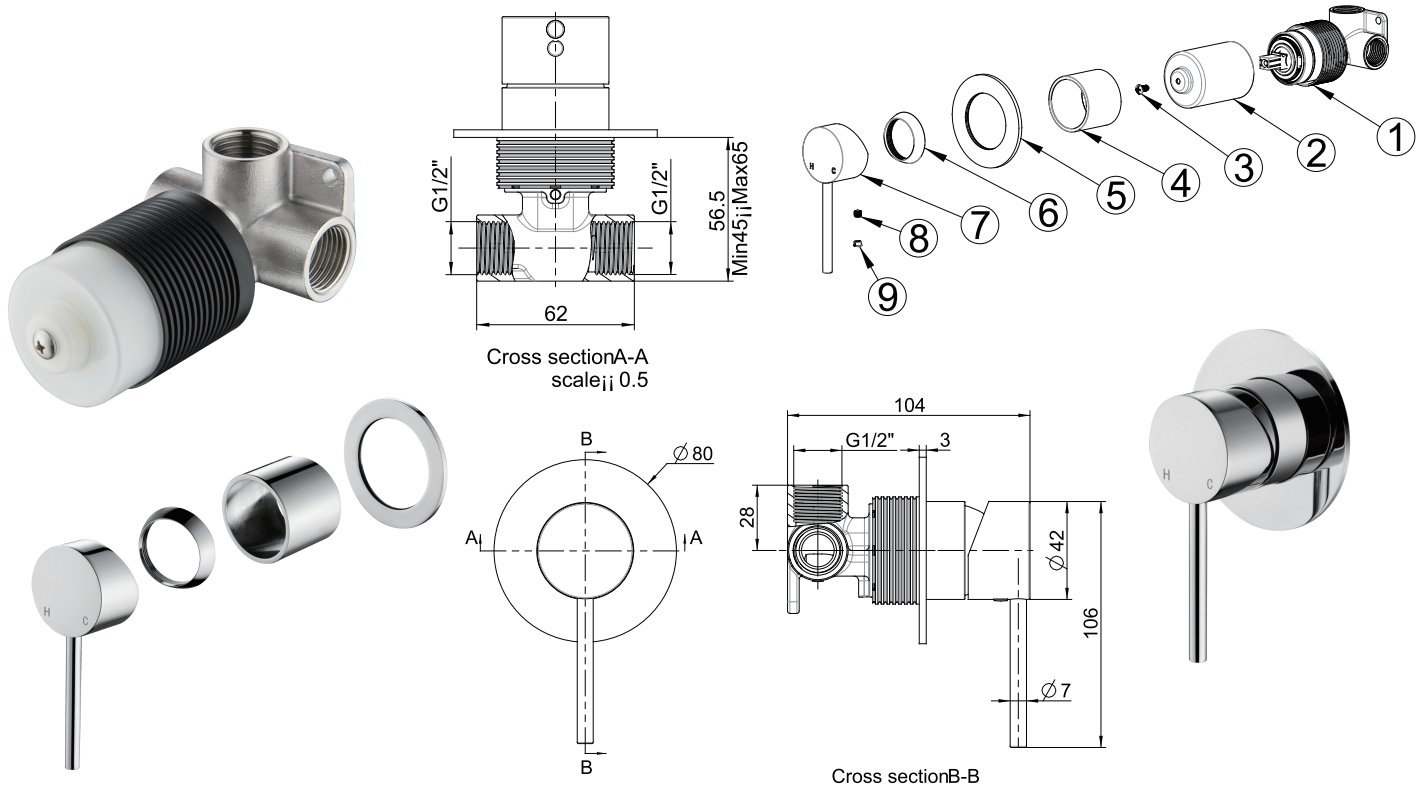

NO.	Description	QTY
1.	Main body	X1
2.	Cover	X1
3.	Screw	X1
4.	Outer Sleeve	X1
5.	Plate	X1
6.	Dome	X1
7.	Handle	X1
8.	Screw M5	X1
9.	Button	X1

General information

1. Prior to installing a tap, all pipes leading to the product must be flushed clean.
2. Products are manufactured as per standard AS/NZS 3718:2021 and with WaterMark & WELS certificate as shown in the packing.
3. All surfaces should be cleaned with water or mild liquid detergent. Do not use cream cleaner or citrus based or chemical cleaning products.



recommended working pressure

0.05-1

Mpa

maximum hot water temperature

55
degrees

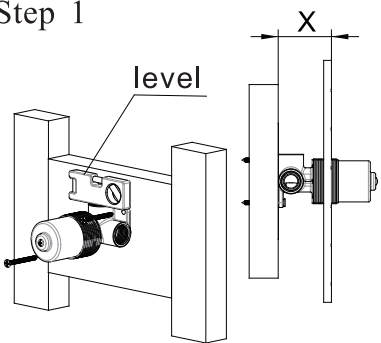
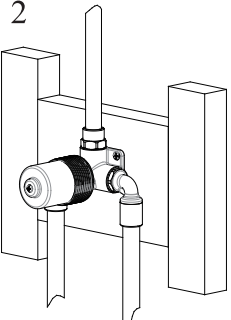
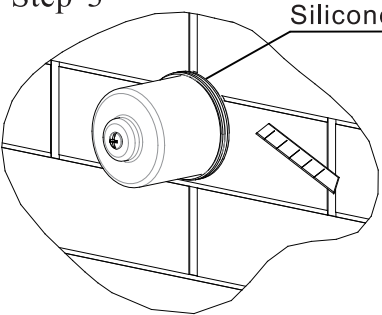
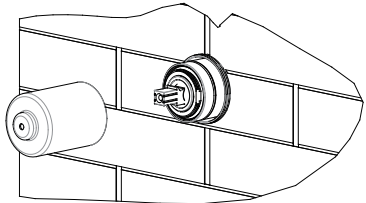
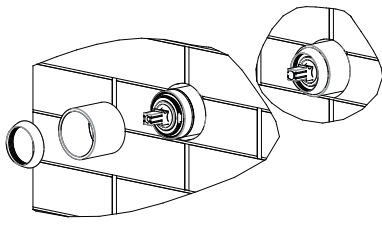
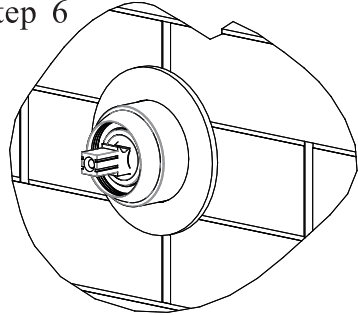
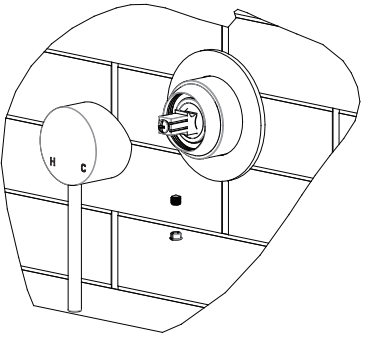
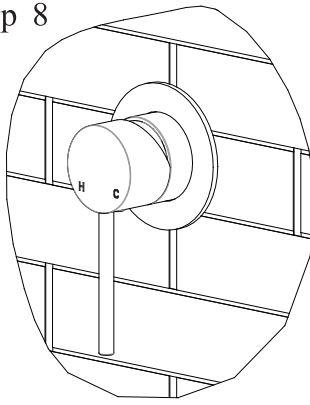

Installation Instruction

<p>Step 1</p>  <p>1. Fix ① on the wall with screws and keep it level. 2. The X distance is 45mm~65mm from the wall to the tile surface.</p>	<p>Step 2</p>  <p>1. Connect the inlet and outlet water pipes according to the mainfunction mark (Suggest use loxead, not tape) 2. According to the standard water pressure test, if there is no leaking, proceed to the next step.</p>	<p>Step 3</p>  <p>1. Add full bead of silicone around mixer. 2. use knife cut the extra plastic sleeve out the wall.</p>
<p>Step 4</p>  <p>Remove ③② parts</p>	<p>Step 5</p>  <p>1. Do silicone oil inside ④ 2. Lock ⑥ onto ①</p>	<p>Step 6</p>  <p>1. Do silicone oil to the o-ring of ⑤ 2. Do Silicone to the back of ⑤ 3. install ⑤</p>
<p>Step 7</p>  <p>Install ⑦⑧⑨</p>	<p>Step 8</p>  <p>Installation complete</p>	

The warranty will be void for any of the following reasons

- The product has been damaged through misuse, neglect or accident.
- The product has not been used in accordance with any applicable instruction guide.
- The purchaser has attempted to modify or repair the product.
- The product is not installed by a Registered Plumber.

▪ Contact Information:

Email: support@acumios.com.au

Website: www.acumios.com.au



ACUMIOS

Round Wall Mixer Trim Kit Installation Instructions

